

2

1

DOOR HANDLE AND DEADBOLT HEIGHT LOCATION

USE JIG FOR SOSS  
 INVISIBLE  
 HINGE MODEL 218 4  
 HINGES  
 USED CENTER OF HINGE  
 IS 6" FROM TOP OR  
 BOTTOM  
 OF DOOR 2 HINGES  
 EQUALITY  
 SPACED BETWEEN TOP  
 AND BOTTOM

SECONDARY HINGE  
 SPECIFICATION  
 COMMERCIAL GRADE  
 SELF CLOSING  
 INDICATIVE CRL 4" X 4"  
 DULL NICKEL  
 HEAVY DUTY SPRING  
 HINGE FINISH  
 SHOULD MATCH LATCH

OPTIONS  
 PEEPHOLE  
 DOOR KNOCKER  
 WOOD ROSETTE  
 ROUTER INCISED  
 DESIGN  
 WOOD OR STONE INLAY

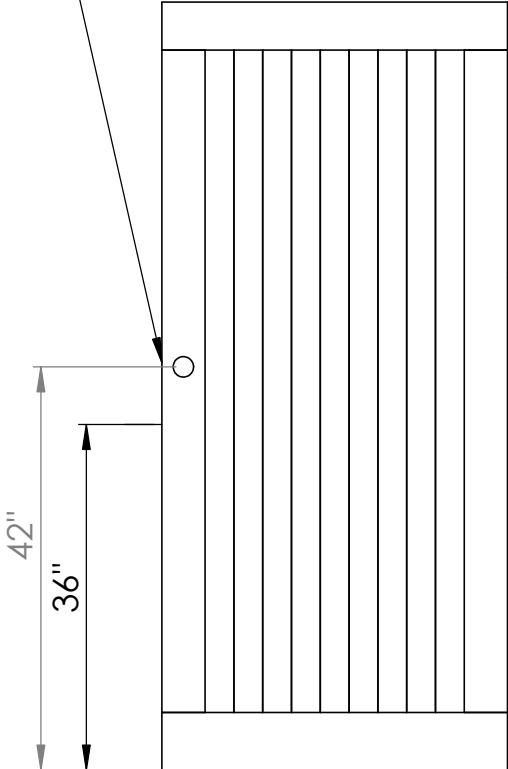
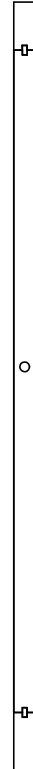

B

B

A

A

|             |         |                                      |   |      |           |
|-------------|---------|--------------------------------------|---|------|-----------|
|             |         | UNLESS OTHERWISE SPECIFIED:          |   | NAME | DATE      |
|             |         | DIMENSIONS ARE IN INCHES             | DRAWN   | AG   | AUG 30/18 |
|             |         | TOLERANCES:                          | CHECKED   |      |           |
|             |         | FRACTIONAL ±                         | ENG APPR.   |      |           |
|             |         | ANGULAR: MACH ± BEND ±               | MFG APPR.   |      |           |
|             |         | TWO PLACE DECIMAL ±                  | Q.A.  |      |           |
|             |         | THREE PLACE DECIMAL ±                | Art Gzebowski Certified<br>Machine Draftsman Engineering Designer<br>T 204 396 2211<br>arthuriski@gmail.com<br><b>3D CAD MODELING BY ART</b><br>user of Solidworks<br>www.3dmodelingbyart.com |      |           |
|             |         | INTERPRET GEOMETRIC TOLERANCING PER: |   |      |           |
|             |         | MATERIAL                             |   |      |           |
|             |         | FINISH                               |   |      |           |
| NEXT ASSY   | USED ON |                                      |   |      |           |
| APPLICATION |         | DO NOT SCALE DRAWING                 |   |      |           |

BOKE CONSULTING

TITLE:  
 SPLINE DOOR, HINGE, DEADBOLT,  
 AND DOOR KNOB LOCATION

**PROPRIETARY AND CONFIDENTIAL**  
 THE INFORMATION CONTAINED IN THIS DRAWING IS THE SOLE PROPERTY OF <BOKE CONSULTING>. ANY REPRODUCTION IN PART OR AS A WHOLE WITHOUT THE WRITTEN PERMISSION OF <BOKE CONSULTING> IS PROHIBITED.

SIZE DWG. NO. REV  
**A** AG000400DB\_ASM 8

SCALE: 1:20 SHEET 8B OF 8

2

1

2

1

B

B

| ITEM NO. | PART NUMBER | DESCRIPTION  | QTY. |
|----------|-------------|--|------|
| 1        | A000111-S   | 2-1/2" X 4-1/2" X 69" DOOR SIDES                       | 2    |
| 2        | A000114-S   | 31/64" X 31/32" X 68" VERT SPLINES                     | 10   |
| 3        | A000112-S   | 2-1/4" X 3" X 69" SPLINE DOOR CENTERS                  | 9    |
| 4        | A000115-S   | 31/64" X 31/32" X 36" SPLINE DOOR TOP & BOTTOM SPLINES | 2    |
| 5        | A000113-S   | 2-1/4" X 5" X 36" SPLINE DOOR TOP                      | 1    |
| 6        | A000117-S   | 2.-1/4" X 6" X 36" SPLINE DOOR BOTTOM KICK PLATE       | 1    |

A

A

**PROPRIETARY AND CONFIDENTIAL**  
 THE INFORMATION CONTAINED IN THIS DRAWING IS THE SOLE PROPERTY OF <BOKE CONSULTING>. ANY REPRODUCTION IN PART OR AS A WHOLE WITHOUT THE WRITTEN PERMISSION OF <BOKE CONSULTING> IS PROHIBITED.

|             |         |                                      |  |           |
|-------------|---------|--------------------------------------|--|-----------|
|             |         | UNLESS OTHERWISE SPECIFIED:          | NAME   | DATE      |
|             |         | DIMENSIONS ARE IN INCHES             | DRAWN  | AG        |
|             |         | TOLERANCES:                          | CHECKED  | AUG 30/18 |
|             |         | FRACTIONAL ±                         | ENG APPR.  |           |
|             |         | ANGULAR: MACH ± BEND ±               | MFG APPR.  |           |
|             |         | TWO PLACE DECIMAL ±                  | Q.A.   |           |
|             |         | THREE PLACE DECIMAL ±                | <b>Art Gzebowski</b> Certified<br>Machine Draftsman Engineering Designer<br>T 204.396.2211<br>arthurisk@gmail.com<br><b>3D CAD MODELING BY ART</b><br>user of Solidworks<br><a href="http://www.3dmodelingbyart.com">www.3dmodelingbyart.com</a> |           |
|             |         | INTERPRET GEOMETRIC TOLERANCING PER: |  |           |
|             |         | MATERIAL                             |  |           |
|             |         | FINISH                               |  |           |
| NEXT ASSY   | USED ON |                                      |  |           |
| APPLICATION |         | DO NOT SCALE DRAWING                 |  |           |

# BOKE CONSULTING

## TITLE: SPLINE DOOR BILL OF MATERIAL

|          |                 |     |
|----------|-----------------|-----|
| SIZE     | DWG. NO.        | REV |
| <b>A</b> | AG000400-S1_ASM |     |

|             |              |
|-------------|--------------|
| SCALE: 1:20 | SHEET 2 OF 8 |
|-------------|--------------|

2

1

2

1

B

B

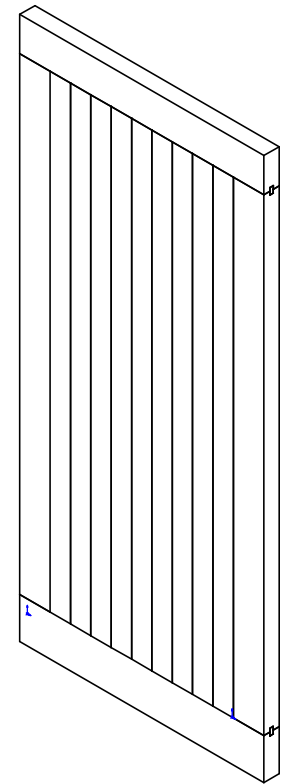
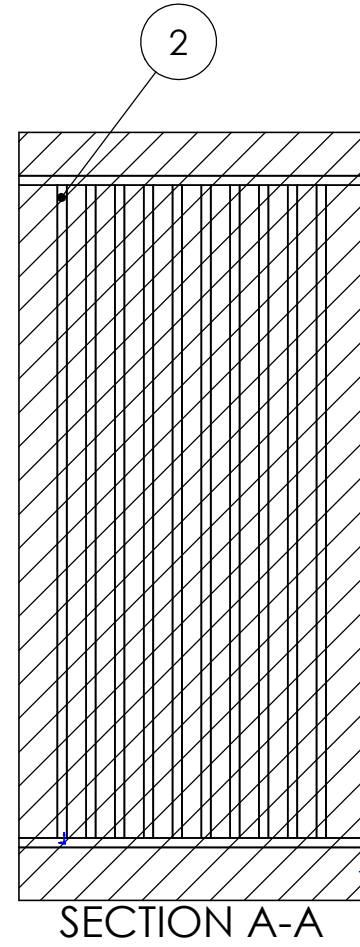
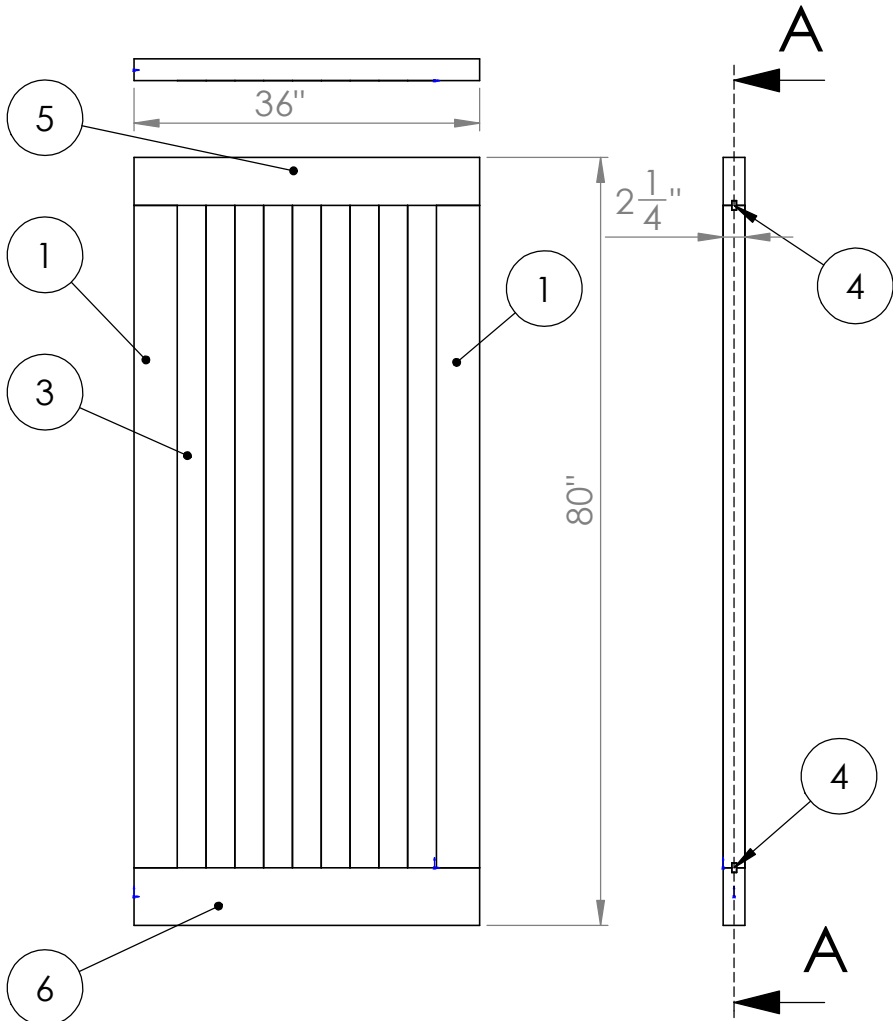

A

A

**PROPRIETARY AND CONFIDENTIAL**  
 THE INFORMATION CONTAINED IN THIS DRAWING IS THE SOLE PROPERTY OF <BOKE CONSULTING>. ANY REPRODUCTION IN PART OR AS A WHOLE WITHOUT THE WRITTEN PERMISSION OF <BOKE CONSULTING> IS PROHIBITED.

|  |             |                                      |  |      |           |
|--|-------------|--------------------------------------|--|------|-----------|
|  |             | UNLESS OTHERWISE SPECIFIED:          |  | NAME | DATE      |
|  |             | DIMENSIONS ARE IN INCHES             | DRAWN  | AG   | AUG 30/18 |
|  |             | TOLERANCES:                          | CHECKED  |      |           |
|  |             | FRACTIONAL ± 1/32"                   | ENG APPR.  |      |           |
|  |             | ANGULAR: MACH ± BEND ±               | MFG APPR.  |      |           |
|  |             | TWO PLACE DECIMAL ±                  | Q.A.   |      |           |
|  |             | THREE PLACE DECIMAL ±                |  |      |           |
|  |             | INTERPRET GEOMETRIC TOLERANCING PER: | <b>Art Gzebowski</b> Certified<br>Machine Draftsman Engineering Designer<br>T 204.396.2211<br>arthurisk@gmail.com<br><b>3D CAD MODELING BY ART</b><br>user of Solidworks<br><a href="http://www.3dmodelingbyart.com">www.3dmodelingbyart.com</a> |      |           |
|  |             | MATERIAL                             |  |      |           |
|  |             | BOREAL FOREST PINE / SPRUCE          |  |      |           |
|  |             | FINISH                               |  |      |           |
|  |             | SAND TO 180 GRIT READY FOR PAINT     |  |      |           |
|  | NEXT ASSY   | USED ON                              |  |      |           |
|  | APPLICATION |                                      | DO NOT SCALE DRAWING   |      |           |

|                                |                 |              |
|--------------------------------|-----------------|--------------|
| BOKE CONSULTING                |                 |              |
| TITLE:<br>SPLINE DOOR ASSY. DR |                 |              |
| SIZE                           | DWG. NO.        | REV          |
| <b>A</b>                       | AG000400-S1_ASM |              |
| SCALE: 1:20                    |                 | SHEET 1 OF 8 |

2

1

B

A

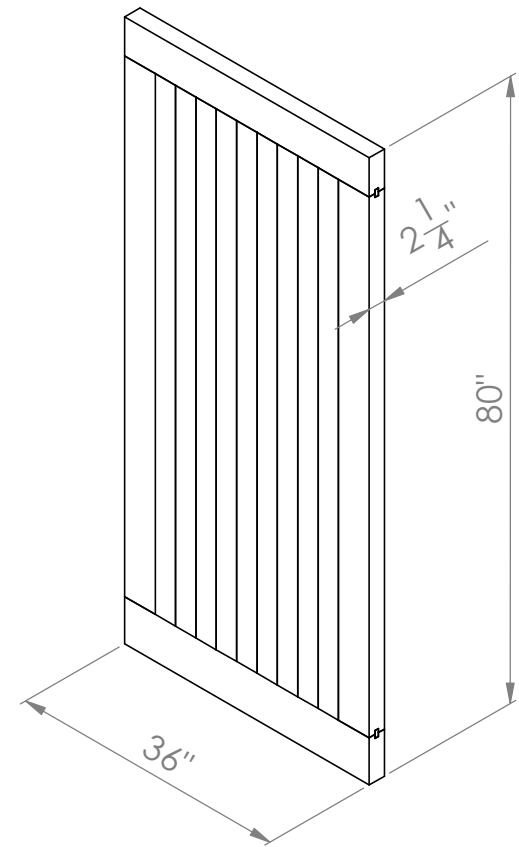
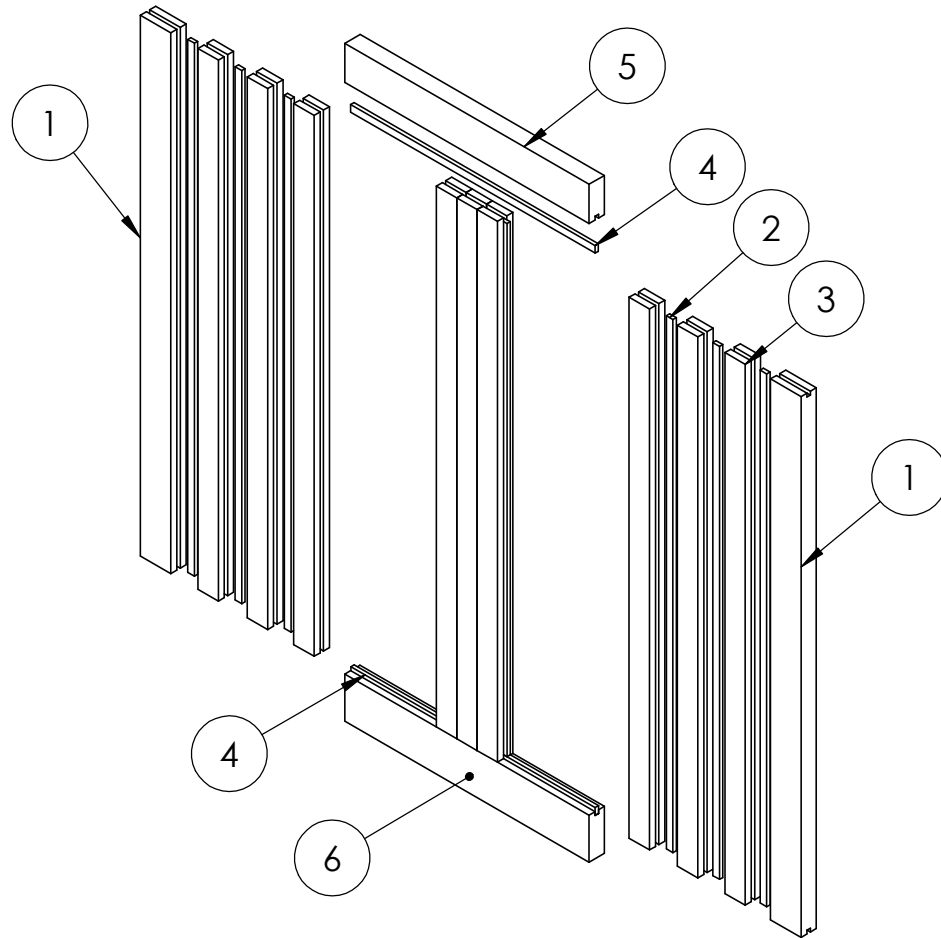

B

A

|  |             | UNLESS OTHERWISE SPECIFIED:          | NAME  | DATE | BOKE CONSULTING |                      |                |     |
|--|-------------|--------------------------------------|---|------|-----------------|----------------------|----------------|-----|
|  |             | DIMENSIONS ARE IN INCHES             | DRAWN   | AG   | AUG 30/18       | TITLE:               |                |     |
|  |             | TOLERANCES:                          | CHECKED   |      |                 | SPLINE DOOR EXPLODED |                |     |
|  |             | FRACTIONAL ±                         | ENG APPR.   |      |                 | VIEW                 |                |     |
|  |             | ANGULAR: MACH ± BEND ±               | MFG APPR.   |      |                 |                      |                |     |
|  |             | TWO PLACE DECIMAL ±                  | Q.A.  |      |                 |                      |                |     |
|  |             | THREE PLACE DECIMAL ±                |   |      |                 |                      |                |     |
|  |             | INTERPRET GEOMETRIC TOLERANCING PER: | <b>Art Gzebowski</b><br>Machine Draftsman Engineering Designer <small>Certified</small><br>T 204.396.2211<br>arthuriski@gmail.com |      |                 | SIZE                 | DWG. NO.       | REV |
|  |             | MATERIAL                             | <b>3D CAD MODELING BY ART</b><br>user of Solidworks<br><a href="http://www.3dmodelingbyart.com">www.3dmodelingbyart.com</a>       |      |                 | <b>A</b>             | AG000400-S_ASM |     |
|  |             | FINISH                               |   |      |                 | SCALE: 1:20          | SHEET 8A OF 8  |     |
|  | NEXT ASSY   | USED ON                              |   |      |                 |                      |                |     |
|  | APPLICATION |                                      | DO NOT SCALE DRAWING  |      |                 |                      |                |     |

**PROPRIETARY AND CONFIDENTIAL**  
 THE INFORMATION CONTAINED IN THIS DRAWING IS THE SOLE PROPERTY OF <BOKE CONSULTING>. ANY REPRODUCTION IN PART OR AS A WHOLE WITHOUT THE WRITTEN PERMISSION OF <BOKE CONSULTING> IS PROHIBITED.

2

1

B

A

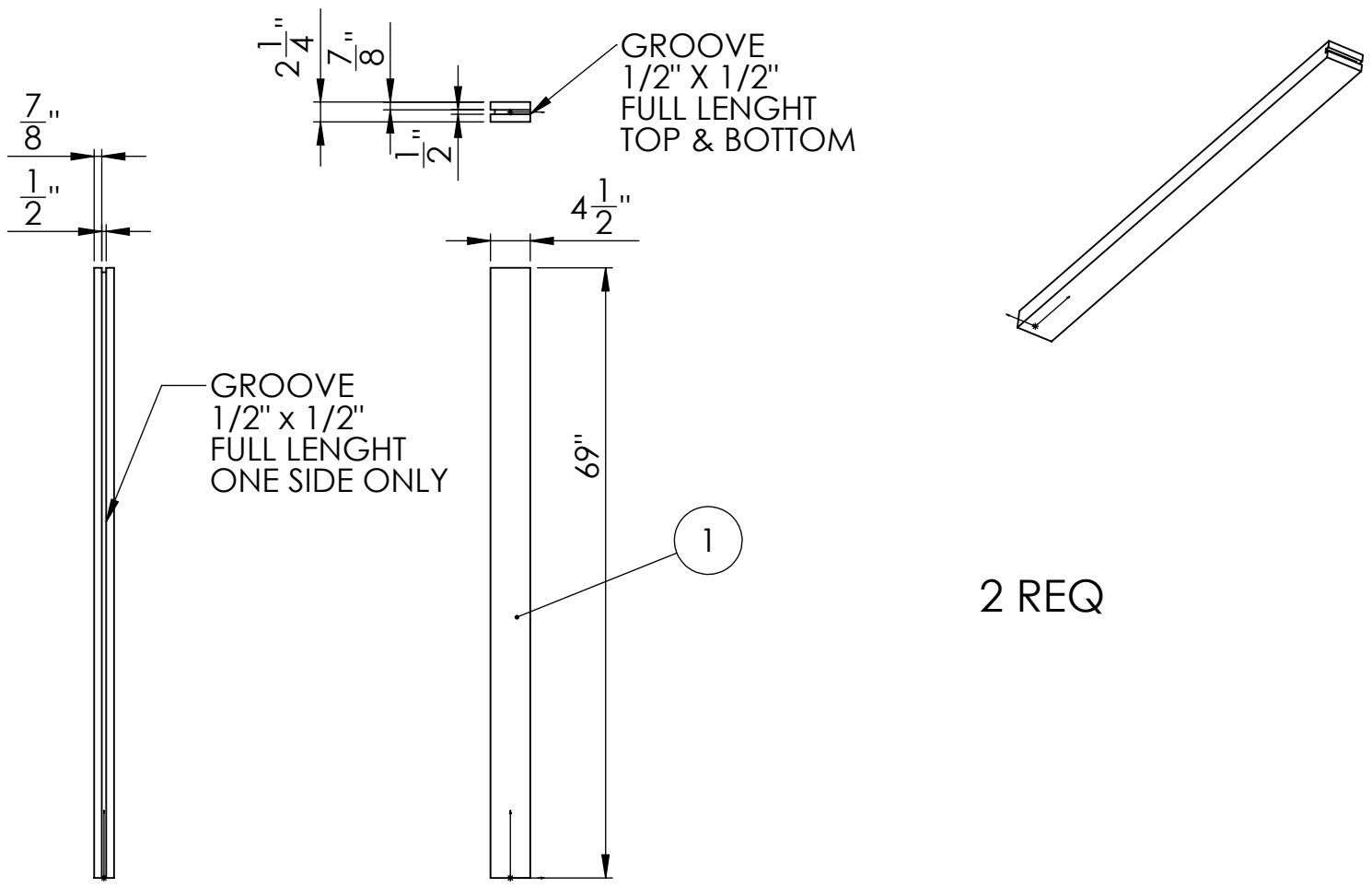

**PROPRIETARY AND CONFIDENTIAL**  
 THE INFORMATION CONTAINED IN THIS DRAWING IS THE SOLE PROPERTY OF <BOKE CONSULTING>. ANY REPRODUCTION IN PART OR AS A WHOLE WITHOUT THE WRITTEN PERMISSION OF <BOKE CONSULTING> IS PROHIBITED.

|             |         |  |           |      |           |
|-------------|---------|--|-----------|------|-----------|
|             |         | UNLESS OTHERWISE SPECIFIED:  |           | NAME | DATE      |
|             |         | DIMENSIONS ARE IN INCHES<br>TOLERANCES:<br>FRACTIONAL ± 1/32<br>ANGULAR: MACH ± BEND ±<br>TWO PLACE DECIMAL ±<br>THREE PLACE DECIMAL ± | DRAWN     | AG   | AUG 13/18 |
|             |         | INTERPRET GEOMETRIC<br>TOLERANCING PER:  | CHECKED   |      |           |
|             |         | MATERIAL<br>BOREAL FOREST PINE/SPRUCE  | ENG APPR. |      |           |
|             |         | FINISH<br>SAND TO 180 GRIT   | MFG APPR. |      |           |
| NEXT ASSY   | USED ON |  | Q.A.      |      |           |
| APPLICATION |         | DO NOT SCALE DRAWING   | COMMENTS: |      |           |

|                            |                       |              |
|----------------------------|-----------------------|--------------|
| BOKE CONSULTING            |                       |              |
| TITLE:<br>SPLINE DOOR SIDE |                       |              |
| SIZE<br><b>A</b>           | DWG. NO.<br>A000111-S | REV          |
| SCALE: 1:20                |                       | SHEET 3 OF 8 |

2

1

2

1

B

B

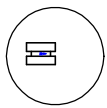

A

3"

7/8"

1/2"

3

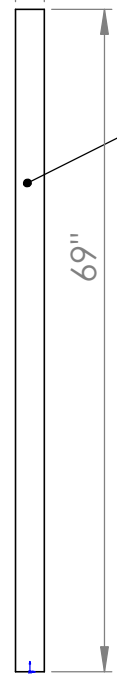

69"

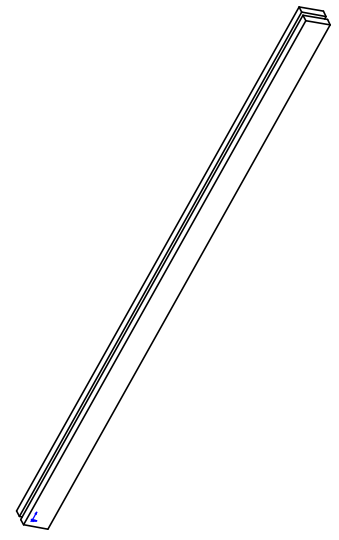
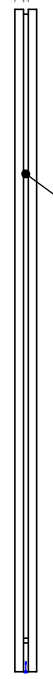

GROOVE 1/2" X 1/2"  
FULL WIDTH  
TOP & BOTTOM

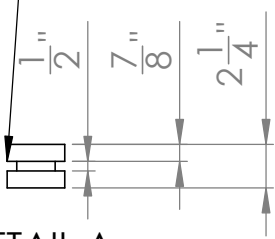

DETAIL A  
SCALE 1 : 10

GROOVE 1/2" X 1/2"  
FULL LENGTH  
BOTH SIDES

9 PCS. REQ.

A

A

|  |             |                                      |           |      |           |
|--|-------------|--------------------------------------|-----------|------|-----------|
|  |             | UNLESS OTHERWISE SPECIFIED:          |           | NAME | DATE      |
|  |             | DIMENSIONS ARE IN INCHES             | DRAWN     | AG   | AUG 13/18 |
|  |             | TOLERANCES:                          | CHECKED   |      |           |
|  |             | FRACTIONAL ± 1/32"                   | ENG APPR. |      |           |
|  |             | ANGULAR: MACH ± BEND ±               | MFG APPR. |      |           |
|  |             | TWO PLACE DECIMAL ±                  | Q.A.      |      |           |
|  |             | THREE PLACE DECIMAL ±                | COMMENTS: |      |           |
|  |             | INTERPRET GEOMETRIC TOLERANCING PER: |           |      |           |
|  |             | MATERIAL                             |           |      |           |
|  |             | BOREAL FOREST PINE / SPRUCE          |           |      |           |
|  |             | FINISH                               |           |      |           |
|  |             | SAND TO 180 GRIT                     |           |      |           |
|  | NEXT ASSY   | USED ON                              |           |      |           |
|  |             |                                      |           |      |           |
|  | APPLICATION | DO NOT SCALE DRAWING                 |           |      |           |

BOKE CONSULTING

TITLE:  
SPLINE DOOR CENTERS

**PROPRIETARY AND CONFIDENTIAL**  
THE INFORMATION CONTAINED IN THIS DRAWING IS THE SOLE PROPERTY OF <BOKE CONSULTING>. ANY REPRODUCTION IN PART OR AS A WHOLE WITHOUT THE WRITTEN PERMISSION OF <BOKE CONSULTING> IS PROHIBITED.

SIZE DWG. NO. REV  
**A** A000112-S

SCALE: 1:20 SHEET 5 OF 8

2

1

2 1

B

B

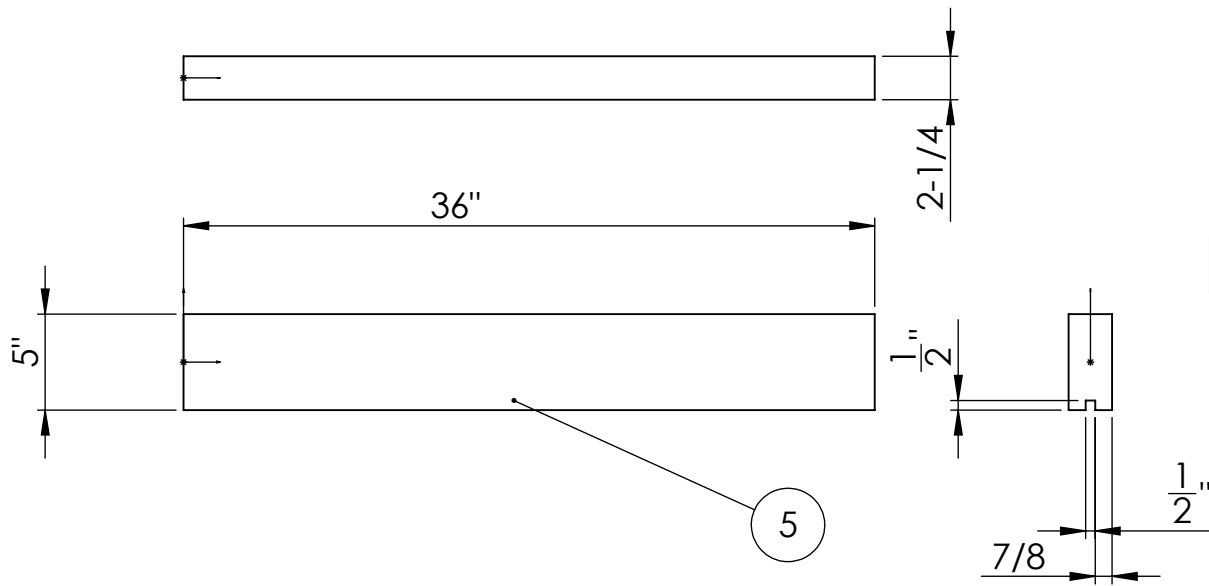

GROOVE 1/2"X1/2"  
FULL LENGHT ONE  
SIDE ONLY

1 PCS. REQ  
TOP

A

A

**PROPRIETARY AND CONFIDENTIAL**  
THE INFORMATION CONTAINED IN THIS  
DRAWING IS THE SOLE PROPERTY OF  
<BOKE CONSULTING>. ANY  
REPRODUCTION IN PART OR AS A WHOLE  
WITHOUT THE WRITTEN PERMISSION OF  
<BOKE CONSULTING> IS  
PROHIBITED.

|             |         |                             |           |      |           |
|-------------|---------|-----------------------------|-----------|------|-----------|
|             |         | UNLESS OTHERWISE SPECIFIED: |           | NAME | DATE      |
|             |         | DIMENSIONS ARE IN INCHES    | DRAWN     | AG   | AUG 13/18 |
|             |         | TOLERANCES:                 | CHECKED   |      |           |
|             |         | FRACTIONAL ± 1/32"          | ENG APPR. |      |           |
|             |         | ANGULAR: MACH ± BEND ±      | MFG APPR. |      |           |
|             |         | TWO PLACE DECIMAL ±         | Q.A.      |      |           |
|             |         | THREE PLACE DECIMAL ±       | COMMENTS: |      |           |
|             |         | INTERPRET GEOMETRIC         |           |      |           |
|             |         | TOLERANCING PER:            |           |      |           |
|             |         | MATERIAL                    |           |      |           |
|             |         | BOREAL FOREST PINE / SPRUCE |           |      |           |
|             |         | FINISH                      |           |      |           |
|             |         | SAND TO 180 GRIT            |           |      |           |
| NEXT ASSY   | USED ON |                             |           |      |           |
| APPLICATION |         | DO NOT SCALE DRAWING        |           |      |           |

**BOKE CONSULTING**

TITLE:  
SPLINE DOOR TOP.

|          |                  |     |
|----------|------------------|-----|
| SIZE     | DWG. NO.         | REV |
| <b>A</b> | <b>A000113-S</b> |     |

|             |              |
|-------------|--------------|
| SCALE: 1:10 | SHEET 7 OF 8 |
|-------------|--------------|

2

1

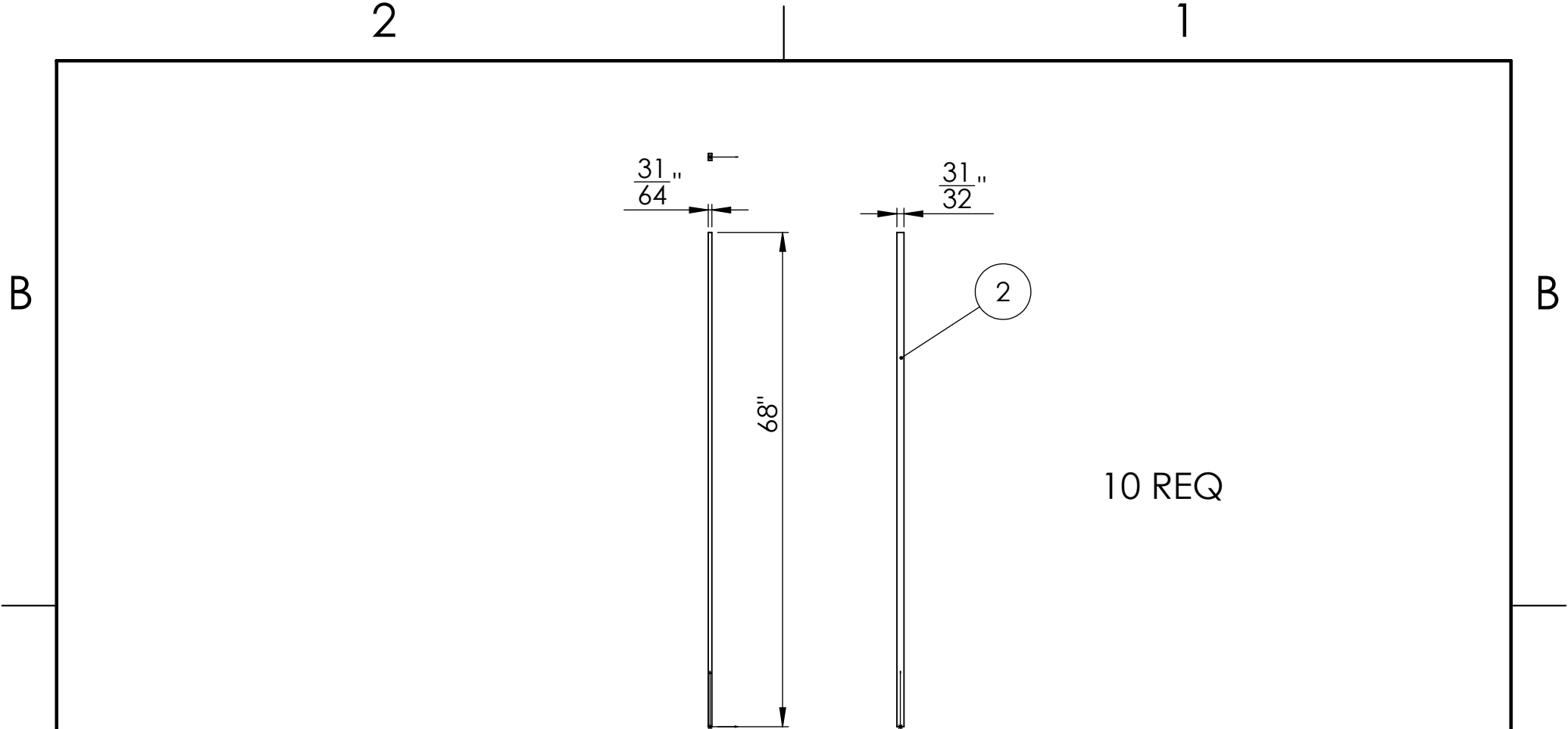

**PROPRIETARY AND CONFIDENTIAL**  
 THE INFORMATION CONTAINED IN THIS DRAWING IS THE SOLE PROPERTY OF <BOKE CONSULTING>. ANY REPRODUCTION IN PART OR AS A WHOLE WITHOUT THE WRITTEN PERMISSION OF <BOKE CONSULTING> IS PROHIBITED.

|             |         |                                      |           |      |           |
|-------------|---------|--------------------------------------|-----------|------|-----------|
|             |         | UNLESS OTHERWISE SPECIFIED:          |           | NAME | DATE      |
|             |         | DIMENSIONS ARE IN INCHES             | DRAWN     | AG   | AUG 15/18 |
|             |         | TOLERANCES:                          | CHECKED   |      |           |
|             |         | FRACTIONAL ± 1/64"                   | ENG APPR. |      |           |
|             |         | ANGULAR: MACH ± BEND ±               | MFG APPR. |      |           |
|             |         | TWO PLACE DECIMAL ±                  | Q.A.      |      |           |
|             |         | THREE PLACE DECIMAL ±                | COMMENTS: |      |           |
|             |         | INTERPRET GEOMETRIC TOLERANCING PER: |           |      |           |
|             |         | MATERIAL                             |           |      |           |
|             |         | BOREAL FOREST PINE / SPRUCE          |           |      |           |
|             |         | FINISH                               |           |      |           |
|             |         | SAW CUT                              |           |      |           |
| NEXT ASSY   | USED ON |                                      |           |      |           |
| APPLICATION |         | DO NOT SCALE DRAWING                 |           |      |           |

|                                     |                  |              |
|-------------------------------------|------------------|--------------|
| BOKE CONSULTING                     |                  |              |
| TITLE:<br>SPLINE DOOR CENTER SPLINE |                  |              |
| SIZE                                | DWG. NO.         | REV          |
| <b>A</b>                            | <b>A000114-S</b> |              |
| SCALE: 1:20                         |                  | SHEET 4 OF 8 |



B

B

2

1

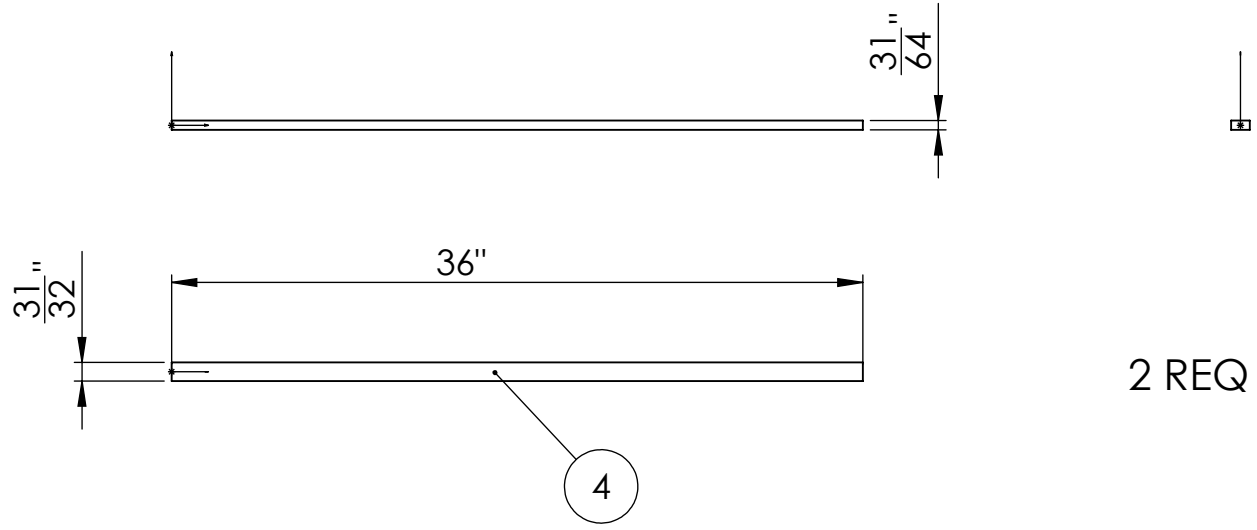

A

A

**PROPRIETARY AND CONFIDENTIAL**  
 THE INFORMATION CONTAINED IN THIS DRAWING IS THE SOLE PROPERTY OF <BOKE CONSULTING>. ANY REPRODUCTION IN PART OR AS A WHOLE WITHOUT THE WRITTEN PERMISSION OF <BOKE CONSULTING> IS PROHIBITED.

|             |         |                                      |           |      |           |
|-------------|---------|--------------------------------------|-----------|------|-----------|
|             |         | UNLESS OTHERWISE SPECIFIED:          |           | NAME | DATE      |
|             |         | DIMENSIONS ARE IN INCHES             | DRAWN     | AG   | AUG 15/18 |
|             |         | TOLERANCES:                          | CHECKED   |      |           |
|             |         | FRACTIONAL ± 1/64"                   | ENG APPR. |      |           |
|             |         | ANGULAR: MACH ± BEND ±               | MFG APPR. |      |           |
|             |         | TWO PLACE DECIMAL ±                  | Q.A.      |      |           |
|             |         | THREE PLACE DECIMAL ±                | COMMENTS: |      |           |
|             |         | INTERPRET GEOMETRIC TOLERANCING PER: |           |      |           |
|             |         | MATERIAL                             |           |      |           |
|             |         | BOREAL FOREST PINE / SPRUCE          |           |      |           |
|             |         | FINISH                               |           |      |           |
|             |         | SAW CUT                              |           |      |           |
| NEXT ASSY   | USED ON |                                      |           |      |           |
| APPLICATION |         | DO NOT SCALE DRAWING                 |           |      |           |

2 REQ

|  |                  |              |
|--|------------------|--------------|
| BOKE CONSULTING                              |                  |              |
| TITLE:<br>SPLINE DOOR TOP AND BOTTOM SPLINES |                  |              |
| SIZE   | DWG. NO.         | REV          |
| <b>A</b>                                     | <b>A000115-S</b> |              |
| SCALE: 1:10                                  |                  | SHEET 6 OF 8 |

2

1

B

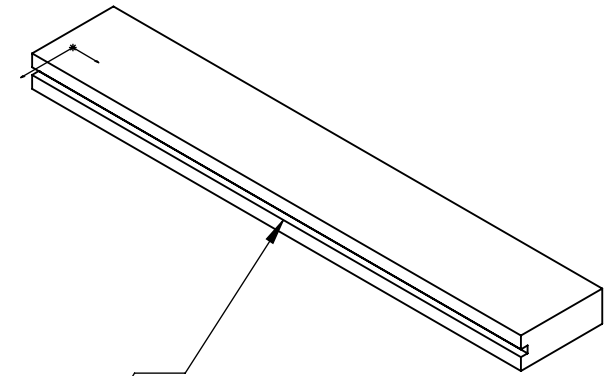
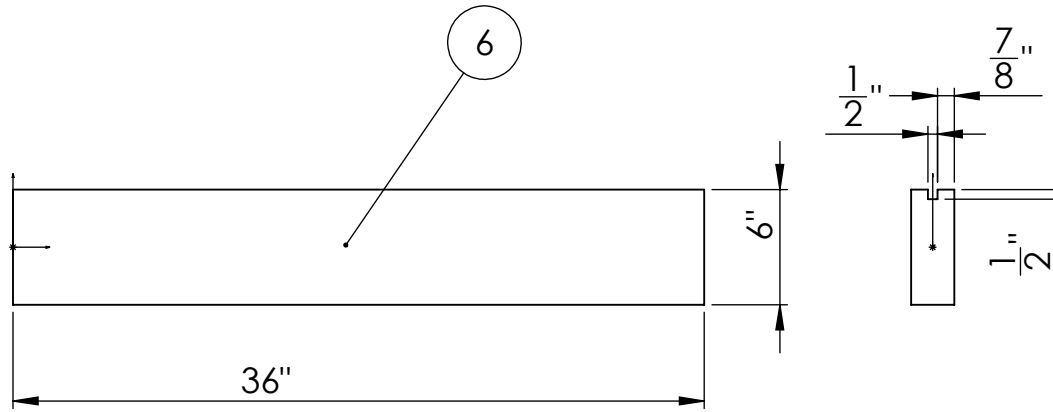

GROOVE 1/2"X1/2"  
FULL LENGTH ONE  
SIDE ONLY

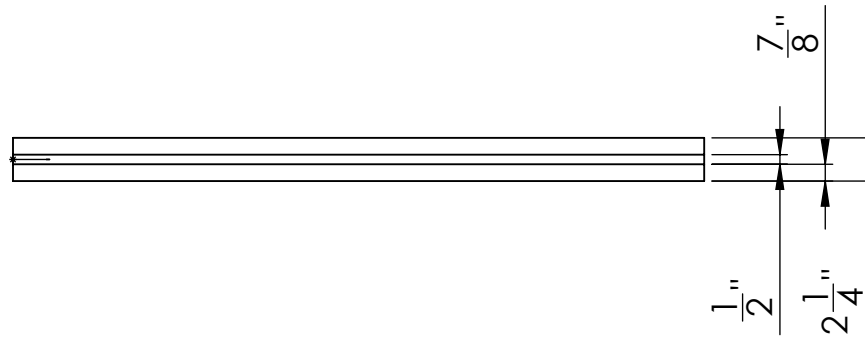

1 REQ.

A

A

**PROPRIETARY AND CONFIDENTIAL**  
THE INFORMATION CONTAINED IN THIS DRAWING IS THE SOLE PROPERTY OF <BOKE CONSULTING>. ANY REPRODUCTION IN PART OR AS A WHOLE WITHOUT THE WRITTEN PERMISSION OF <BOKE CONSULTING> IS PROHIBITED.

|             |         |   |           |      |           |  |                  |              |
|-------------|---------|---|-----------|------|-----------|--|------------------|--------------|
|             |         | UNLESS OTHERWISE SPECIFIED:   |           | NAME | DATE      | BOKE CONSULTING                            |                  |              |
|             |         | DIMENSIONS ARE IN INCHES<br>TOLERANCES:<br>FRACTIONAL $\pm 1/32"$<br>ANGULAR: MACH $\pm$ BEND $\pm$<br>TWO PLACE DECIMAL $\pm$<br>THREE PLACE DECIMAL $\pm$ | DRAWN     | AG   | AUG 15/18 | TITLE:<br>SPLINE DOOR BOTTOM<br>KICK PLATE |                  |              |
|             |         | INTERPRET GEOMETRIC<br>TOLERANCING PER:   | CHECKED   |      |           |  |                  |              |
|             |         | MATERIAL<br>BOREAL FOREST PINE/SPRUCE   | ENG APPR. |      |           |  |                  |              |
|             |         | FINISH<br>SAND TO 180 GRIT  | MFG APPR. |      |           |  |                  |              |
| NEXT ASSY   | USED ON |   | Q.A.      |      |           |  |                  |              |
| APPLICATION |         | DO NOT SCALE DRAWING  | COMMENTS: |      |           | SIZE                                       | DWG. NO.         | REV          |
|             |         |   |           |      |           | <b>A</b>                                   | <b>A000117-S</b> |              |
|             |         |   |           |      |           | SCALE: 1:10                                |                  | SHEET 8 OF 8 |

2

1